

OPERATION & MAINTENANCE GUIDE FOR WINDOWS AND DOORS





Operation & maintenance guide for windows and doors
2020

by ALUPROF S.A.
www.aluprof.eu

OPERATION & MAINTENANCE GUIDE

FOR WINDOWS AND DOORS

4 Care & maintenance guide for ALUPROF S.A. aluminium system elements

- 4 Storage
 - 4 Transport
 - 4 Aluminium profiles
-

7 Incorrect operation of windows and doors

8 Correct operation of windows

12 Correct operation of doors

15 Care & maintenance guide for hardware

- 17 Maintenance of windows and doors—general recommendations
- 17 Maintenance of windows
- 17 Maintenance of single and double doors
- 18 Self-closer
- 18 Hardware for lift & slide doors and sliding doors
- 18 Corrosion protection
- 18 Protection against constantly humid air present in the room
- 18 Dust protection
- 19 Cleaning

CARE & MAINTENANCE GUIDE FOR ALUPROF S.A. ALUMINIUM SYSTEM ELEMENTS

Powder-coated and anodised profiles and profile-based products may be used in normal atmospheric conditions (without aggressive liquids, gases, dusts). When painted and anodised constructions are installed near the coast (less than 5 km), in a rural environment, in an environment exposed to industrial emissions or in a place exposed to chemicals or moisture (swimming pools, laboratories, etc.), special rules for painted and anodic coating thickness apply.

STORAGE



Profiles should be stored in dry, clean places, free from chemically active vapours and gases.

TRANSPORT



Profiles should be transported in covered, dry and clean means of transport equipped with air suspension. During the transport, profiles must be protected from damage and adverse weather conditions.

ALUMINIUM PROFILES



(organic solvents, concentrated alcohol, acids, bases, and petroleum-derived compounds)



(sharp tools and abrasives)

Powder and oxide coatings are not resistant to mechanical damage caused by sharp tools and abrasives.

Powder and oxide coatings are sensitive, i.e. to organic solvents, concentrated alcohol, acids, bases, and petroleum-derived compounds. Avoid contact with the above-mentioned substances.



In particular, coatings must be protected against contact with lime, cement and other alkaline building materials.

Compounds for sealing joints and other auxiliary materials, such as fillers and putties, lubricants and coolants used for cutting and drilling, adhesives, jointing mortars, sealants, sellotapes, etc. that are in contact with the coatings must be pH-neutral and must not contain substances that are harmful to the applied paint or oxide layer. The sun intensifies aggressive chemicals. Therefore, the above-mentioned materials should be tested for suitability before use.



Leaving the protective film on profiles, on the surface of the powder coating during the transport, especially when exposed to the sun and high temperature, can lead to chemical reactions leading to the fusion of the powder coating with the film. As a result of this reaction, the film cannot be removed without damaging the powder coating. Remove the protective film from profiles immediately after receipt of material.



In addition to weather-related factors (sun, frost, precipitation), aluminium profiles in external walls of buildings are exposed to aggressive air components and are therefore elements on which pollutants accumulate. Therefore, components must be cleaned regularly, at a frequency that depends on the location of the construction. The frequency of cleaning depends on many factors:

- building's geographical location
- the environment in which the building is located, e.g. seaside, industrial, acid/basic, etc.
- the degree of atmospheric pollution,
- wind zone,
- the degree of protection of the building by neighbouring buildings,
- the transferability of particles (especially sand) that cause erosion of the coating,
- if the environmental conditions change during the building's operation, e.g. from rural to industrial environment.

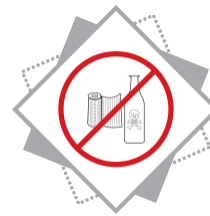

Cleaning is often a cause of defects in coating and therefore you should follow the rules described below:

1. Cleaning should be done at least twice a year. Cleaning must be documented in a report. Cleaning must be done by qualified professionals.
2. The recommended method of cleaning of powder-coated surfaces is to wash them regularly with a solution of mild detergent (eg 5% dishwashing liquid) in warm water. All surfaces should be cleaned with a soft sponge or cloth. Do not use brushes harder than those with natural bristles (for convenience, window cleaning may be carried out simultaneously). After washing, the surface should be rinsed thoroughly with clean water.
3. After washing and rinsing, anodised surfaces can be polished with a dry, soft cloth to restore gloss, and, when dealing with strong local dirt, polished with a lightly abrasive polishing paste and protected with a delicate layer of a special preservative, not containing wax, petroleum jelly, lanolin or similar substances.
4. In order to remove hardly removable stains (caused by atmospheric pollutants) from painted surfaces, it is recommended to use petroleum ether. In this case, you must not use abrasive materials (sandpaper, polishing paste), or solvents containing ketones, esters or alcohols.
5. For cleaning, use clean water. Cleaning may be more effective if you use non-scratching cloth to wipe the decorative surface.

6. While cleaning, the temperature of the coatings must not exceed 25° C.
7. The temperature of the water used for cleaning must not exceed 25° C. Do not clean the coating using a jet of steam.
8. Before cleaning, the surface should be checked for possible adverse effect of the cleaning agent. The test should be carried out on invisible surfaces. In case of adverse effects, do not use the tested cleaning agent.
9. Under no circumstances should cleaning agents below 5pH or above 8pH be used.
10. Do not use highly acidic or highly alkaline cleaning agents (this includes agents that contain detergents) as well as surface-active agents which can react with the aluminium.
11. Do not use abrasive cleaners and do not clean the surface by friction. It is allowed to use soft cotton cloth, intended for industrial cleaning. While wiping, do not force too much the cloth to the cleaned surface.
12. Do not use organic solvents containing esters, ketones, alcohols, aromatics, glycol esters, chlorinated hydrocarbons, and the like.
13. Do not use detergents of unknown origin.
14. Do not use salt and chemical substances to remove ice formations near the profiles.
15. The maximum exposure time of the cleaning agent must not exceed one hour. If necessary, cleaning process can be repeated after 24 hours.
16. After each cleaning, the surface must be immediately rinsed with clean cold water.
17. Regular washing prevents the formation of intense dirt that is very difficult to remove. For external applications, where a decorative appearance and protective function are particularly important, eg portals, store fronts, etc., weekly cleaning is recommended. In this case, it is possible to use water and chamois (suede) for cleaning, then wipe the elements from top to bottom with a soft, dry cloth.
18. Window frames, window sills and façades must be cleaned regularly. Cleaning frequency depends on the aggressiveness of the environment and of the structure of the façade.
19. Gaskets should be maintained regularly, the maintenance frequency depends on their exposure to environmental factors. Remove any soiling from the gaskets before maintenance. After maintenance, use commercially available EPDM rubber protection agents.



INCORRECT OPERATION OF WINDOWS AND DOORS

a) no other load shall be applied to the window casement

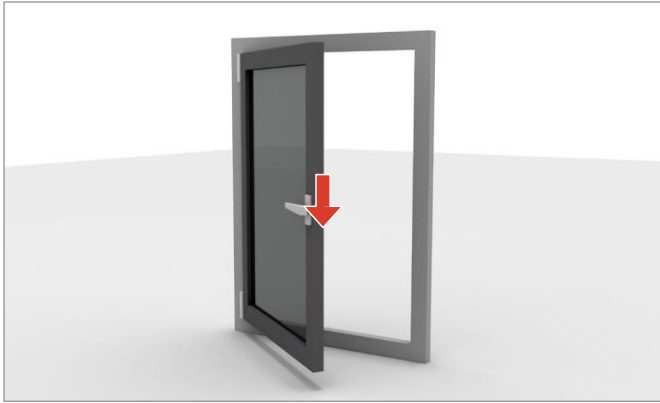

b) do not press the window casement against the reveal

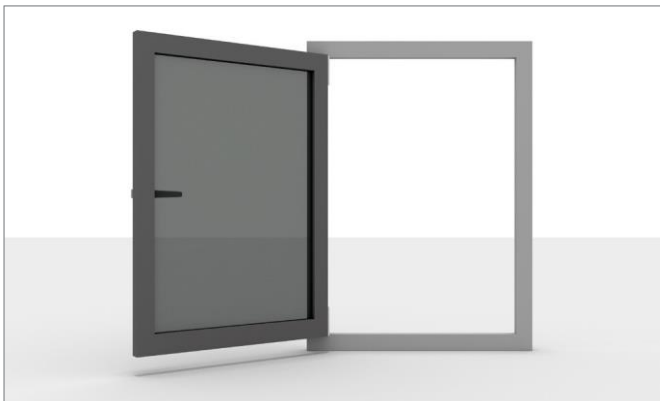

c) snapping casement can lead to injury, do not put your hand between casement and frame when closing the window



d) a lockable handle or a stay must be fitted if the window is accessed by children or persons with mental disabilities



e) do not leave the window open in strong winds



CORRECT OPERATION OF WINDOWS

a) side-hung window

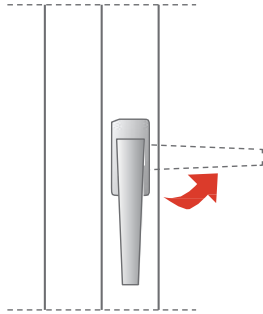

b) tilt-and-turn window

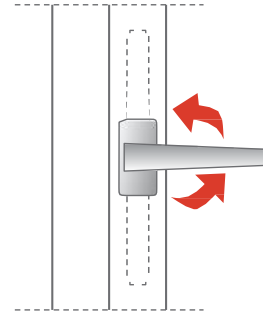

c) tilt-and-turn window

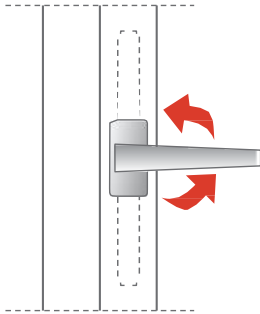

d) bottom-hung window with handle on the side

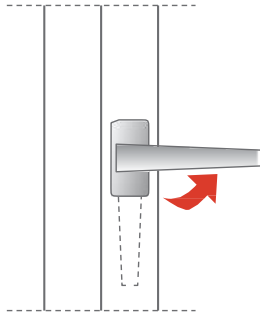

e) pivot window with horizontal pivot axis

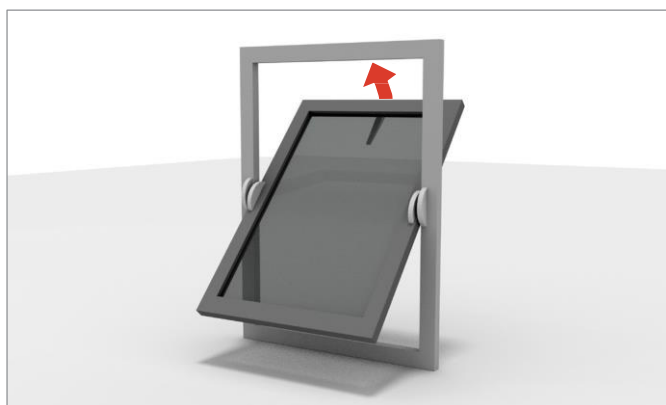
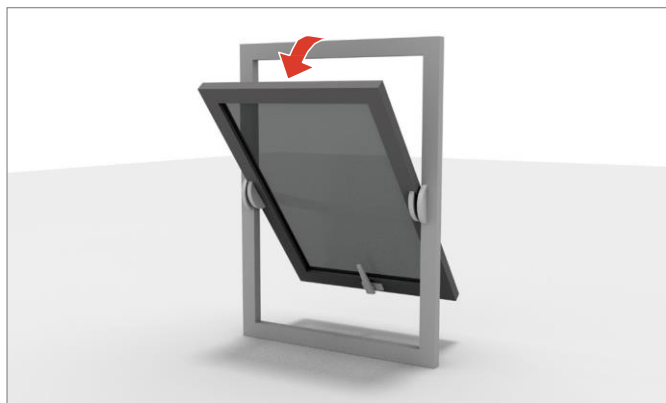
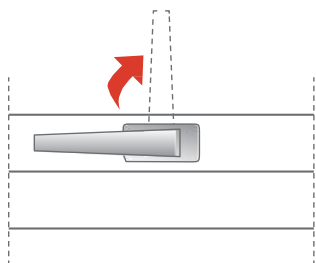

f) pivot window with vertical pivot axis

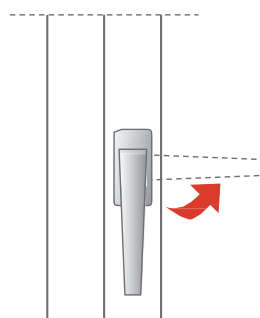

g) tilt-and-slide window

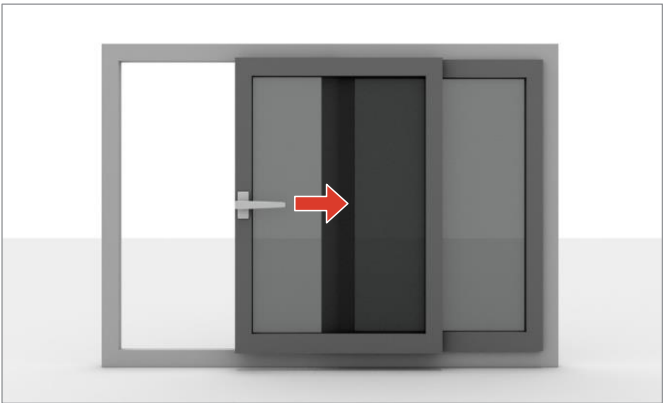
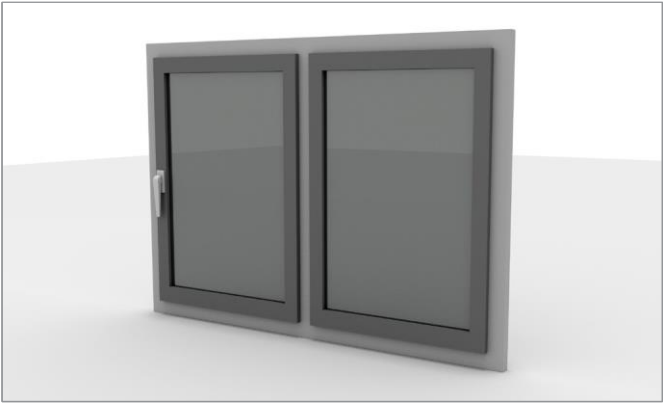
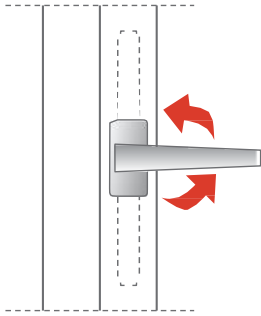

h) top-hung window

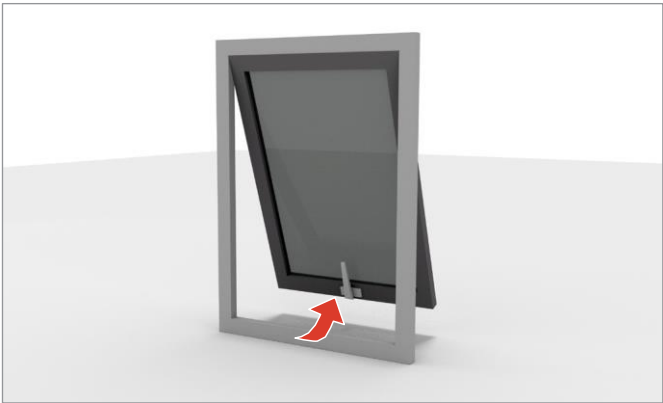
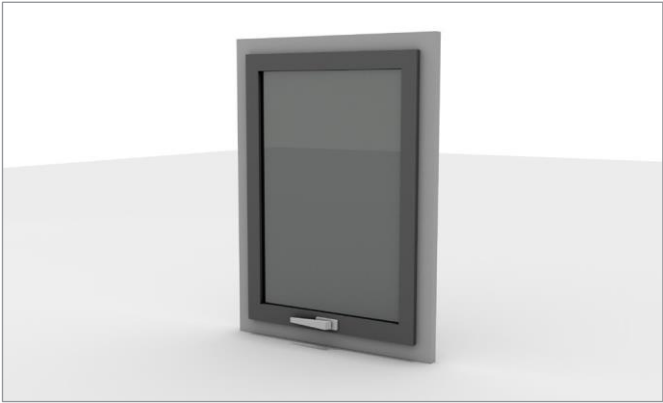
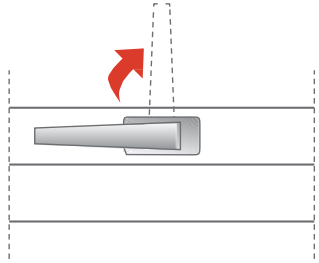

CORRECT OPERATION OF DOORS

a) single door

To open the door, place the key in the lock's opening and turn it towards the hinges. Press the handle and then pull it as you open it in the direction you stand on, or push it when you open the door in the opposite direction. If you want to close the door, perform the steps described above in reverse order, bearing in mind that the double turn of the key locks the lock.

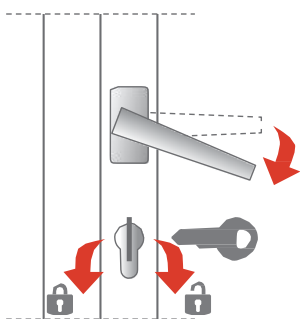

b) double door

Double door is an "extended" single door with an additional, "inactive" leaf. To open it, first open the active leaf in accordance with "single door" description and then unlock the bolts. To close the door, perform the steps described above in reverse order.



c) panic door

The door is opened by means of panic devices (levers, bars) by pressing them and pushing the door.



d) sliding door

Doors can be equipped with a fixed handle (unlocked by turning the cylinder) and an integrated handle, which can be unlocked by moving the internal mechanism of the handle (green marker: "handle open"; red marker: "handle closed").

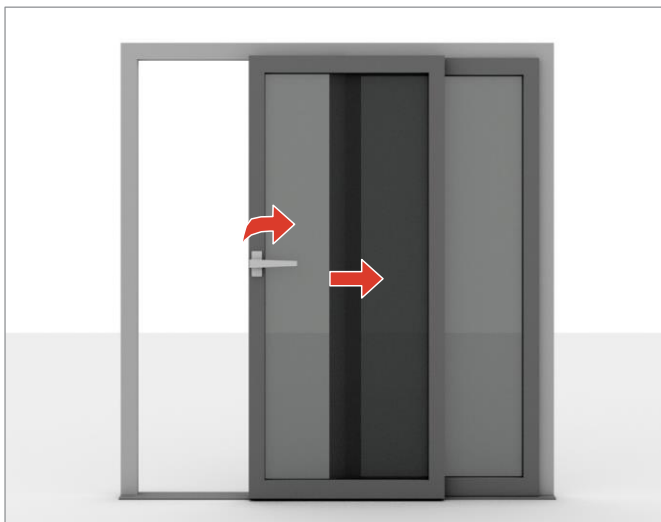

e) lift & slide door

The door opens by turning the handle by 180°, which causes the leaf to go up and be operated freely.

If the door is equipped with an additional insert, unlock it first and then turn the handle by 180°.

The door closes in reverse order.

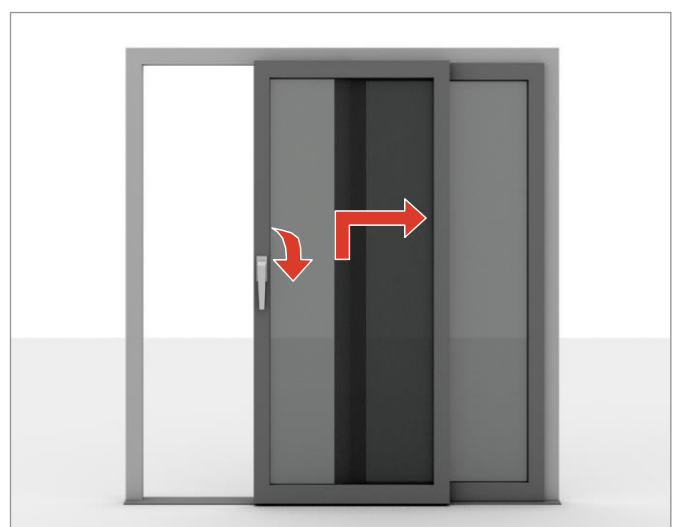

f) folding door

Doors can be fabricated in different configurations, marked with digits. The first digit indicates the total number of leaves in a set, the second digit—the number of leaves folded to the left (looking from the outside), and the third digit—the number of leaves folded to the right.

The configurations: 3-3-0; 3-0-3; 3-2-1; 3-1-2; 5-5-0; 5-4-1; 5-3-2; 5-2-3 are fabricated with an active leaf, i.e. they have a door lock and, when opening this leaf, you should follow the description for "single door", with the exception that the angle of opening is close to 180°, which means that you can open them on the adjacent leaf.

The configurations: 4-3-1; 4-1-3; 6-5-1; 6-1-5; 6-3-3 are fabricated

with active and inactive leaf, when opening these doors, follow the instructions for "double door".

The remaining leaves of the construction open as follows: if the handle has an insert, it should first be unlocked with a key and then the handle should be turned by 90° (as shown in the drawing) in order to reach the horizontal position from the threshold. The next step is to pull the door handle inwards when the door opens, inwards, or push it when the door opens outwards. This will cause the adjacent leaves to slip off together. The order of opening of individual leaves is shown in the drawing.

Close the door in the reverse order to that described above.

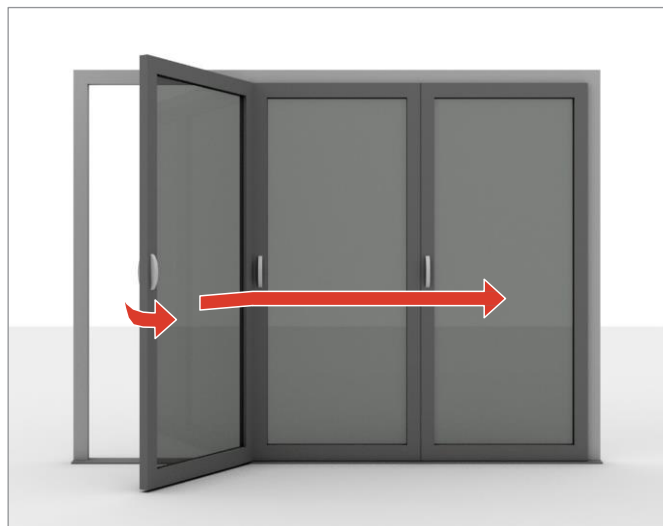

CARE & MAINTENANCE GUIDE FOR HARDWARE

Maintenance and adjustment of the system fittings must be carried out in accordance with the recommendations and at a frequency mentioned in the maintenance & adjustment manuals provided by their manufacturers.

SYSTEM MAINTENANCE FOR WATER DRAINAGE

Check for weephole blockages and clear them if necessary. Remove all dirt, sand and solids with a vacuum cleaner. Repeat it every 6 months or more frequently if necessary.

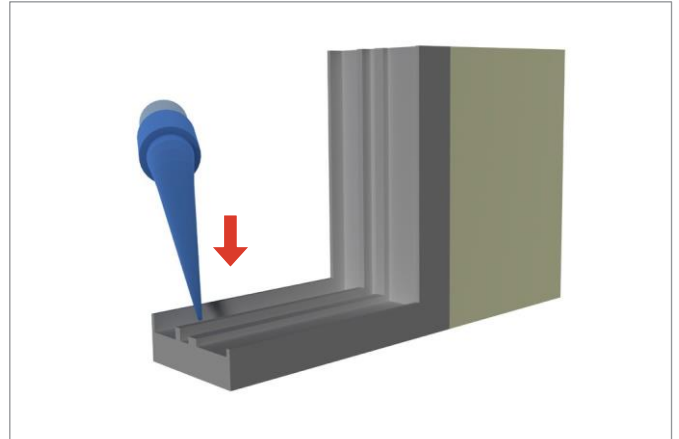

MAINTENANCE OF THE LOWER FRAME AND GUIDE TRACKS IN SLIDING DOOR, LIFT & SLIDE DOOR AND FOLDING DOOR

All soilings such as dirt, sand, gravel, solids, etc. should be removed with a vacuum cleaner from the lower frame and guide track. This must be done at least once a month. Once a year, clean the whole, i.e. the frame and the guide track, with a cloth.

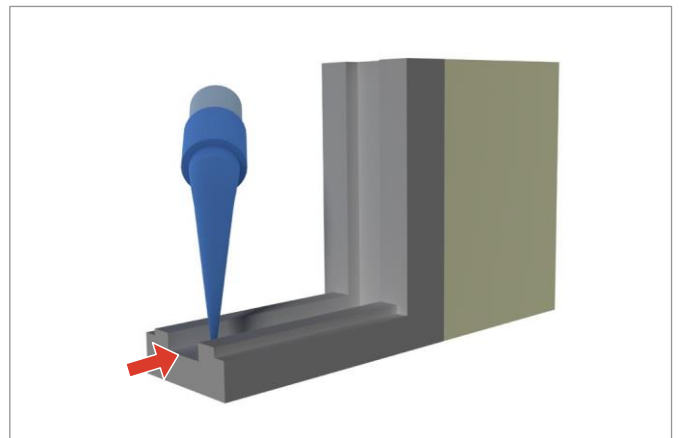

MAINTENANCE OF SEALS AND GASKETS

Check the condition of seals and gaskets. Replace if damaged. To ensure that the gaskets remain soft and do not stick to the frame, a small amount of talcum powder or liquid silicone should be applied.

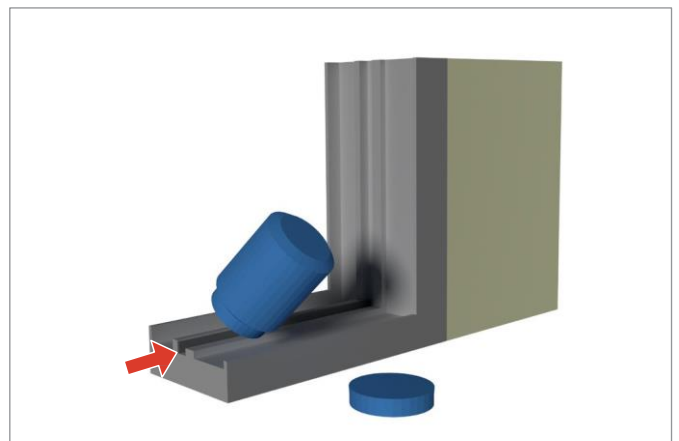

MAINTENANCE OF HARDWARE



IMPORTANT!

Danger of injury from improperly performed maintenance work!

Improper maintenance can lead to severe body injuries or damages to objects.

- before starting maintenance work, provide sufficient space for installation work.
 - maintain order and cleanliness at the installation site.
 - during maintenance, secure windows and balcony doors against unintentional closing or opening.
 - the adjustment of hardware components, replacement, removal and installation of the leaf must be carried out by qualified service personnel.
 - leaf should not be removed for maintenance work.
-

CONTROL

**At least once a year,
in hotels and schools—every six months:**

Check the stability of the fastening of safety-relevant hardware components.

Check the wear and tear of safety-relevant hardware components.

Check the correct operation of all movable hardware components.

Check the correct operation of all locking points.

By operating the window handle, you can verify if the multi-point locking system works smoothly.

- Locking and unlocking moment in accordance with DIN 18055: max. 10 Nm.
- A torque wrench can be used for verification purposes.
- The operation of locking mechanism can be greatly improved by lubrication, oiling or re-adjustment of the hardware.



PLEASE NOTE

Observe the following environmental precautions during maintenance:

- clean the lubrication points of excess oil and dispose of it in accordance with environmental regulations.
 - pour the replaced oil into suitable containers and dispose of it in accordance with environmental guidelines.
-

MAINTENANCE OF WINDOWS AND DOORS

GENERAL RECOMMENDATIONS

At least once a year, in hotels and schools—every six months:

Check all elements for correct operation.

Check all screws and handle stability, tighten the fixing screws if necessary.

Replace damaged screws. If necessary, replace worn/damaged parts with original ones and adjust the hardware in order to restore proper operation of the leaf/casement.

Only use cleaning agents that are free of corrosive substances.

For cleaning window elements, use mild, pH-neutral, diluted cleaning agents. Never use cleaning agents and scouring agents containing acids. They may affect the protective layer.

MAINTENANCE OF WINDOWS

Lubricate all moving parts with machine oil or grease free of resins and acids, available from specialised retail outlets.

Lubricate steel strikes with machine oil or grease without resins and acids, available from specialist dealers.

Lubricants (preferably sprayed) should be introduced into each aperture of the hardware. After lubrication, open/operate the window several times until the grease is distributed and wipe off any excess grease. Lubricate the strikes on the frame, at the point of entry of the hardware bolt, using a constant-consistency grease

The corner transmission, handle and mishandling device are greased during manufacture and therefore no additional lubrication is necessary.

The (pushed) connection rods should not be lubricated in the groove.

Pivot bearings **MUST NOT** be lubricated or oiled—this applies to the maintenance of pivot windows.

MAINTENANCE OF SINGLE AND DOUBLE DOOR

All moving parts and locking elements must be oiled regularly.

Lock cylinder should be maintained only with graphite powder.

Door hinges do not require maintenance or oiling.

**Maintenance must be carried out by
qualified service personnel.**

SELF-CLOSER

Check the wear and tear of the components regularly for proper operation. If irregularities are found, tighten the mounting screws or replace defective parts.

At least once a year:

Oil all parts of the self-closer arm.

Check the self-closer adjustments.

HARDWARE FOR LIFT & SLIDE DOORS AND SLIDING DOORS

Remove dirt, dust, sand, etc., which may adversely affect the functioning of the door.

Lubricate or oil all moving parts and locking points.

Use only grease or oil without acid and resins.

To prevent alterations to the hardware surface, we recommend using protective agents.



IMPORTANT!

These should be carried out exclusively by the maintenance:

- replacement of hardware
 - installation / removal of casements/leaves
 - hardware adjustment
-

CORROSION PROTECTION

Avoid contact with aggressive vapours (e.g. formic or acetic acid, ammonia, reaction of amines and ammonia, aldehydes, phenols, tannic acids, etc.).

In addition, do not use seals containing acidic or acetic substances or the components mentioned above, as both direct contact with the seal and its vapours can cause corrosion of the hardware surface.

PROTECTION AGAINST (CONSTANTLY) HUMID AIR PRESENT IN THE ROOM

In the construction phase, hardware and notches must have access to air, especially during installation, so that they are not directly exposed to moisture or condensation.

Ensure that there is no permanent condensation of water vapour in the space between the leaf and the frame:

- Air intensively several times a day (open all windows for about 15 minutes).
- Ensure sufficient air exchange, also during holidays and public holidays.

DUST PROTECTION

Do not let the dust from building materials gather on the hardware.

CLEANING

Sediments on the hardware surface and impurities from building materials (mortar dust, gypsum, cement, etc.) should be removed with water before they get concentrated.

Do not use aggressive, abrasive and acidic cleaning agents.

Clean only with mild, diluted, pH-neutral detergents.

Clean only with a soft cloth.

These recommendations shall not give rise to legal consequences and should be applied on a case-by-case basis.

The manufacturer of windows and balcony doors must inform property owners and window users about this maintenance manual.

Window joinery manufacturers are recommended to have windows installed only by professional and trained technical personnel and to always provide finished windows with hardware operation & maintenance manuals.



ALUPROF S.A. Bielsko-Biała Manufacturing Facility, ul. Warszawska 153, 43-300 Bielsko-Biała,
Tel +48 33 81 95 300, Fax +48 33 82 20 512, **Opole Manufacturing Facility**, ul. Gostawicka 3, 45-446 Opole,
Tel +48 77 400 00 00, Fax +48 77 400 00 06, **Goeszów Manufacturing Facility**, ul. Przemysłowa 10,
43-440 Goleszów, Tel +48 33 483 20 10, Fax +48 33 81 95 222, E-mail: aluprof@aluprof.eu



www.aluprof.eu